



**PERFORMANCE DATA SHEET
NEMA PREMIUM NR CAN NEMA 12 - 12**

Catalogue #: MQP-68

HP	kW	Voltage	S.F. @ 60Hz	EFF.	P.F.	Frame	Design	L.R. Amps
60	44,76	230/460	1,15	94,5%	0,81	404T	B	435

60 Hz								Code	F.L. RPM
208	230	416	460	480	575	600			
/	146	/	73,00	/	/			G	1190

50 Hz								
FLA			S.F. @ 50Hz	Efficiency	Power Factor	Code	F.L. RPM	
190	380	415						
176,0	88		1,00	93,6%	0,820	E	990	

Wgt. Lbs	PH	Duty	Insul. Class	Amb.	Elevation	Temp. Rise° C
1000	3	Cont.	F	40°C	1000M (3,300 Ft)	< 80

% Efficiency		% Power Factor		Torque		Winding Resist. Ω	Safe Cold Start (Secs)
Full Load:	94,5%	Full Load:	0,81	Full Load Ft/Lbs	264,8		
3/4 Load:	94,5%	3/4 Load:	0,78	Locked Rotor %	150		
1/2 Load:	94,0%	1/2 Load:	0,70	Break Down %	250	0	20

Rotor Inertia Wk2 Lb-Ft2	Max Load Inertia Wk2 Lb-Ft2	Shaft Material	Frame Material	DE Bracket Type	ODE Bracket Type	Enclosure	NEMA Rating	Lead Wire Size
23,73	1120	1045	Cast Iron	Cast Iron	Cast Iron	TEFC	IP55	7AWG

Ball Bearings		Grease	Mount Type	Orientation	Paint	Sound Pressure @ 3FT	Sound Power
DE	ODE						
NU318	6314	Mobil PolyrexEm	Rigid	Horizontal	RAL6022	78	90

Inverter Duty, Motor meets MG1 parts 31.4.4.2	VFD SF	Constant Torque Range	Variable Torque Range	Constant HP RPM
	1,00	10:1	20:1	1800

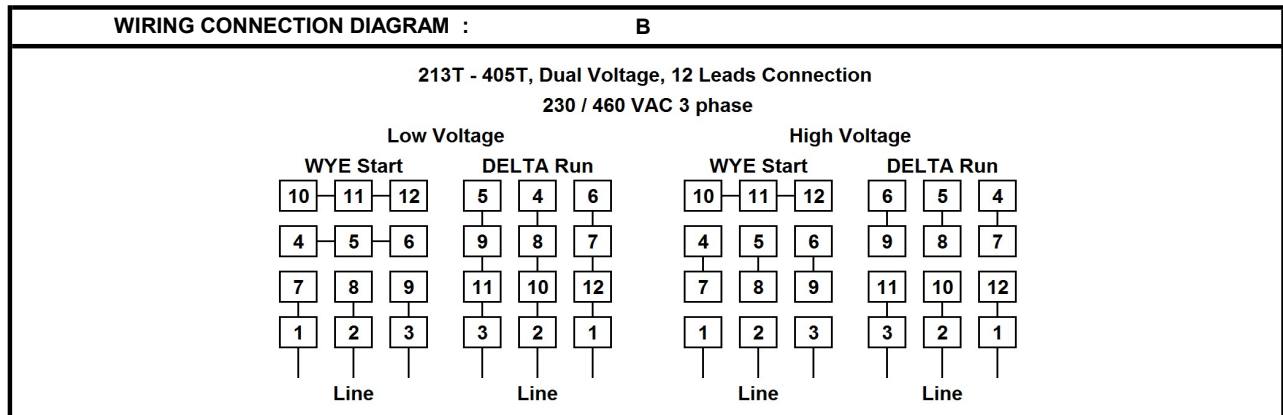

Date: 2023-12-13
 Customer: _____
 Contact: _____
 Submittee: J.C. Lavallée

Catalogue #: MQP-68

NEMA PREMIUM NR CAN NEMA 12 - 12										
HP	VAC	RPM	Enclosure	Frame	Frequency	Design	Poles	LR Code Letter	Insulation Class	Temp. Rise °C
60	460	1190	TEFC	404T	60 Hz	B	6	G	F	< 80
	0Hz	6Hz	15Hz	30Hz	45Hz	60 Hz	75Hz	90Hz	105Hz	120Hz
Amps	73	73	73	73	73	73	73	73	73	73
RPM	0	119	297,5	595	892,5	1190	1487,5	1785	2082,5	2380
Torq ft.lb	211,85	211,85	264,81	264,81	264,81	264,81	211,85	176,54	151,32	132,40
Peak Tq ft.lb	297,91	595,82	595,82	595,82	595,82	595,82	476,65	397,21	340,47	297,91
HP	0	4,8	15,0	30,0	45,0	60,0	60,0	60,0	60,0	60,0
	Locked Rotor	Pull-Up	Breakdown	Rated Load	Idle	Duty	S. F.	Ambient	Elevation	dBa @ 1M
Speed (RPM)	0,0	504	960	1190	1200	Continuous	1,15	40°C	3,300 ft	78
Current (Amps)	435,0	369,8	258,8	73,0	27,7	VFD Rating: Meets MG1 parts 31.4.4.2				
Torque (ft.-lbs)	397,2	297,9	662,0	264,8	0,0	C.T.	10:1	V.T.	20:1	VFD SF 1.00

Motor Speed Data

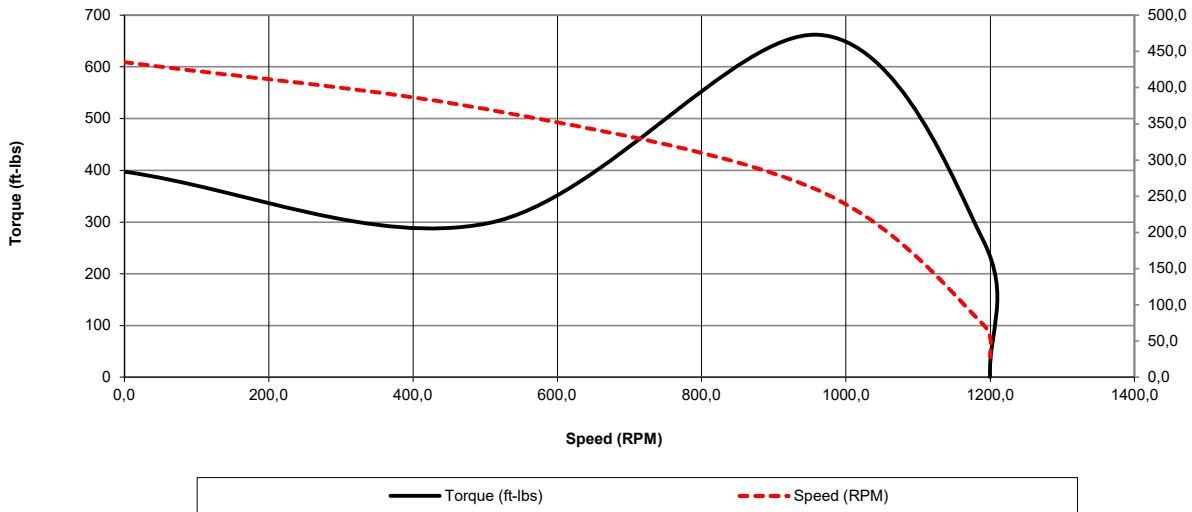

Motor Torque Capability vs RPM

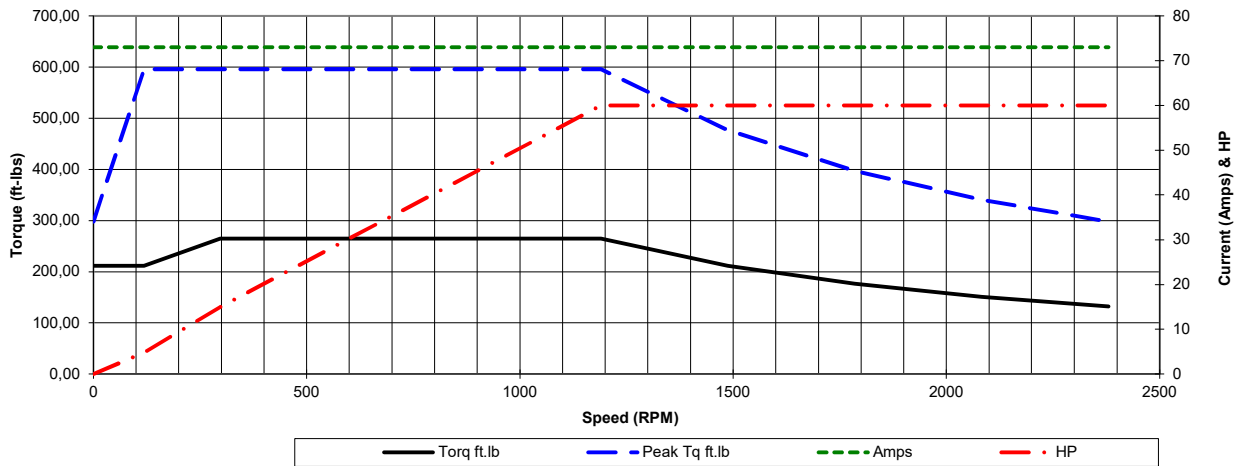



Date: 2023-12-13
 Customer: _____
 Contact: _____
 Submittee: J.C. Lavallée

Catalogue #: MQP-68

NEMA PREMIUM NR CAN NEMA 12 - 12										
HP	VAC	RPM	Enclosure	Frame	Frequency	Design	Poles	LR Code Letter	Insulation Class	Temp. Rise °C
60	460	1190	TEFC	404T	60 Hz	B	6	G	F	< 80

Load %	0%	25%	50%	75%	100%	125%	150%
Amps	27,74	26,10	43,22	57,01	73,00	92,29	113,43
Torq ft/lbs	0	65,79	131,85	198,19	264,81	331,71	398,89
RPM	0	1197,5	1195	1192,5	1190	1187,5	1185
Eff	0	82,80	94,00	94,50	94,50	93,01	92,65
PF	0	65	70	78	81	81,81	80,19

	Locked Rotor	Pull-Up	Breakdown	Rated Load	Idle	Duty	S. F.	Ambient	Elevation	dBA @ 1M
Speed (RPM)	0	504	960	1190	1200	Continuous	1,15	40°C	3,300 ft	78
Current (Amps)	435	369,8	258,8	73	27,74	VFD Rating: Meets MG1 parts 31.4.4.2				
Torque (ft-lbs)	397,21	297,91	662,02	264,81	0,0	C.T.	10:1	V.T.	20:1	VFD SF 1.00

